



Before assembly

- We recommend that time is taken to read the instructions before starting assembly, then follow the easy step by step guide. The instruction sheet is only a guide to the assembly. Certain items may not be shown to scale.
- Check all components prior to assembly
- This product should be assembled by no less than two people.
- Never attempt to erect the assembly in high winds.
- Drill components where indicated.

RECOMMENDED BASE AREA
A recommended base area of no less than 1870mm x 2450mm



Recommended tools for assembly

- Cross head screw driver
- Hammer
- Sharp knife
- Drill
- 4mm diameter drill bit
- Spirit level
- Silicon sealant
- Step ladder

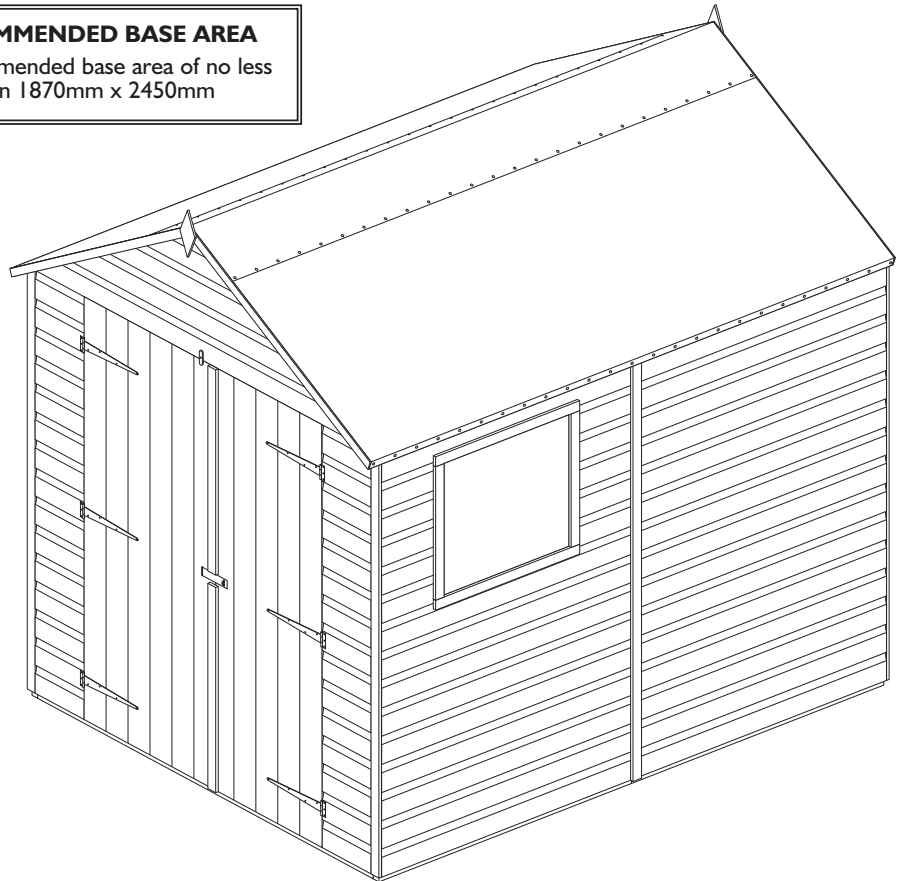

No.	Components	Qty.
1	Floor panel	2
2	Short floor bearer (29 x 29 x 1174mm)	4
3	Long floor bearer (29 x 29 x 1710mm)	10
4	Window panel	1
5	Large plain panel	4
6	Small plain panel	1
7	Right front panel	1
8	Left front panel	1
9	Apex panel	2
10	Door header rail (29 x 29 x 1182mm)	1
11	Roof rafter	8
12	Roof panel	6
13	Roof gusset	4
14	Felt batten (29 x 29 x 1213mm)	4
15	Felt batten block	4
16	Left door	1
17	Right door	1
18	Roof felt (5m)	1
19	Ridge felt (2.5m)	1
20	Coverstrip (12 x 40 x 1730mm)	7
21	Window perspex (560x610mm)	1
22	Plastic beading (560mm)	2
23	Window Coverstrip (12 x 40 x 670mm)	2
24	Window Coverstrip (12 x 40 x 540mm)	2
25	Door coverstrip (12 x 40 x 830mm)	2
26	Bardgeboard	4

No.	Fixing kit	Qty.
27	Finial	2
28	T-hinge (254mm)	6
29	Turn button	1
30	Hasp and staple	1
31	Towerbolt	2
32	63mm Screws	16
33	50mm screws	40
34	38mm screws	16
35	25mm screws	42
36	22mm screws	7
37	19mm round head screws	19
38	30mm nails	167
39	20mm nails	6
40	10mm felt nails	120

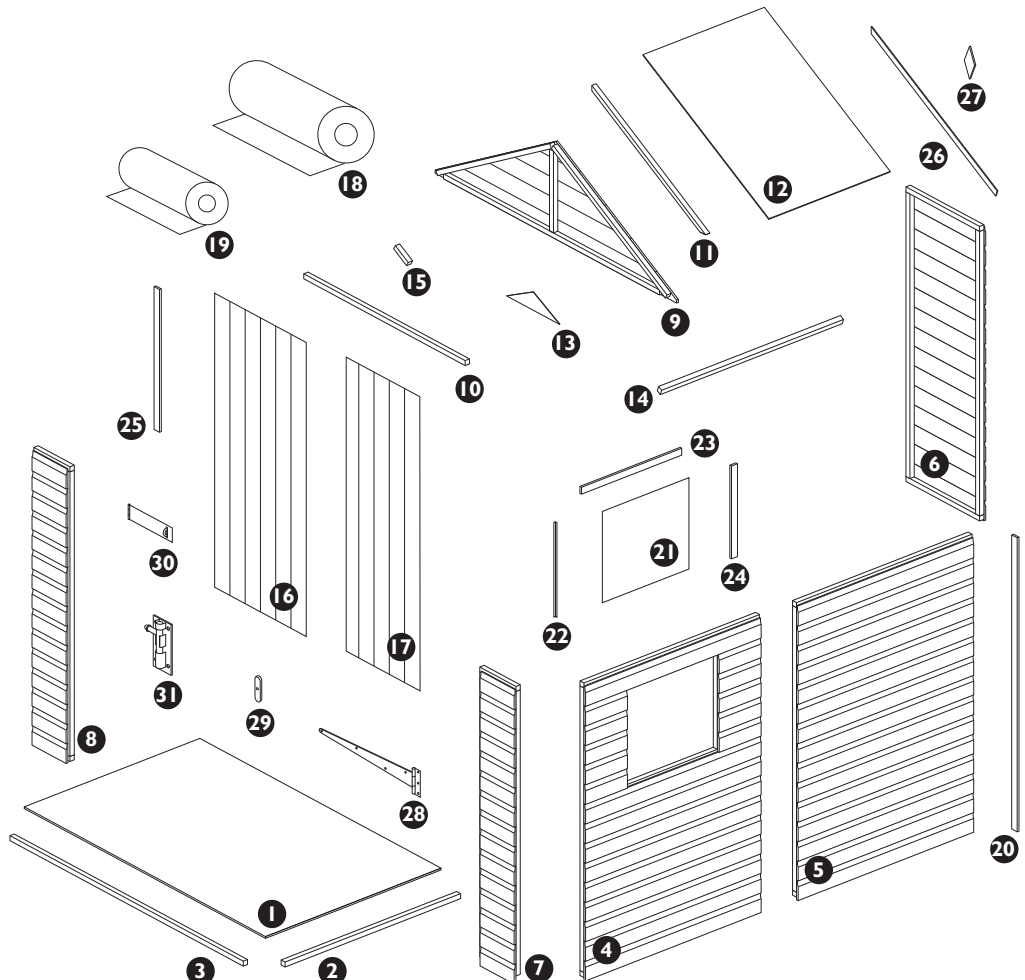

1. Laying the floor section

Prepare a level area of no less than 1870 x 2450mm for the shed to sit. To the bottom of both floor panels, attach the short floor bearers flush with the short edge of the floor using 5 x 30mm nails, nail through the floor panel into the bearers. In the same way attach to each floor panel five long floor bearers between the short bearers as shown using 8 x 30mm nails per bearer. With the two floor panels upside down, join together using 5 x 50mm screws.

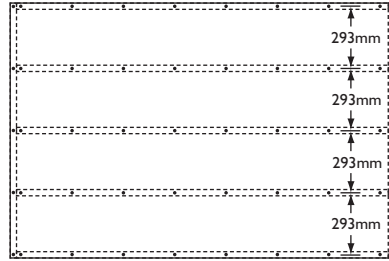
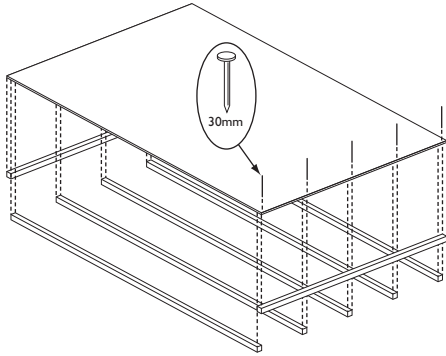

Important note

To "VALIDATE" the guarantee, adequate provision must be made to ensure ground contact is avoided and air is able to circulate underneath the building.

Placing the building on a concrete pad or slab base is acceptable provided that the building is not allowed to sit in pooled water during wet conditions.

If the building is to sit on soil or grass it **MUST** be erected on additional pressure treated wooden 50mm x 50mm or similar bearers (**These are NOT supplied in the kit**).

Rowlinson Garden Products recommend using pressure treated bearers with all buildings on any type of base.

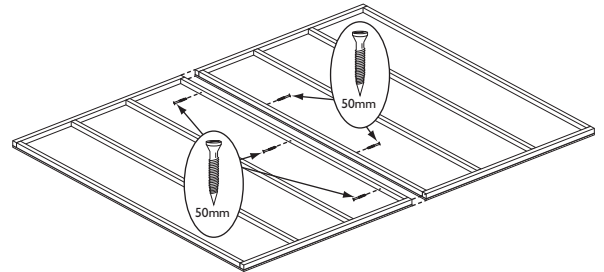

2. Fixing the wall panels together

Position a large panel and the small panel as shown. Note how the panel frames sit on the floor with the panel cladding overhanging the floor edge. Ensure square and secure using 3 x 50mm screws, screw through the frame of the small panel, into the frame of the large panel. Continue to add panels as shown below securing each one with 3 x 50mm screws. It is important to note that the front panels must be orientated correctly so that the framing creates a rebate for the door to fit in.



It is recommended to drill pilot holes with a 4mm drill for each screw.

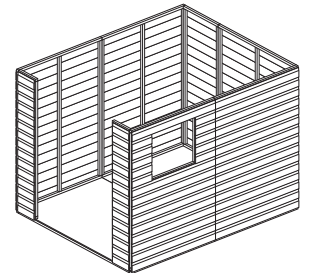
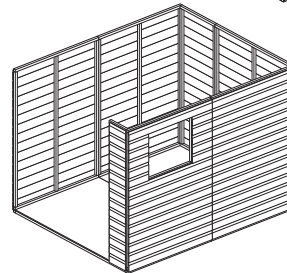
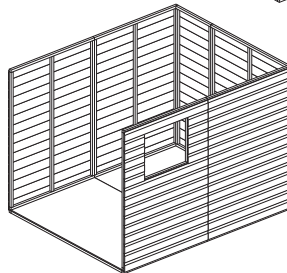
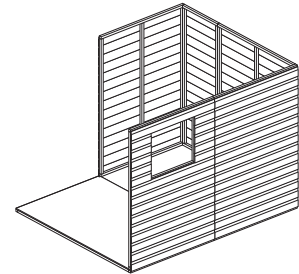
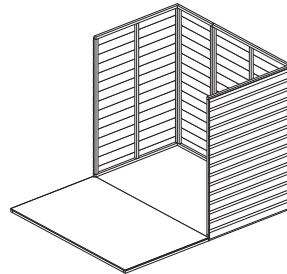
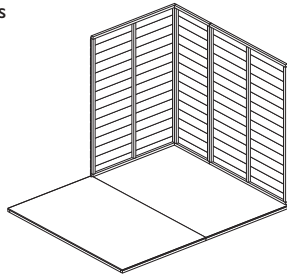
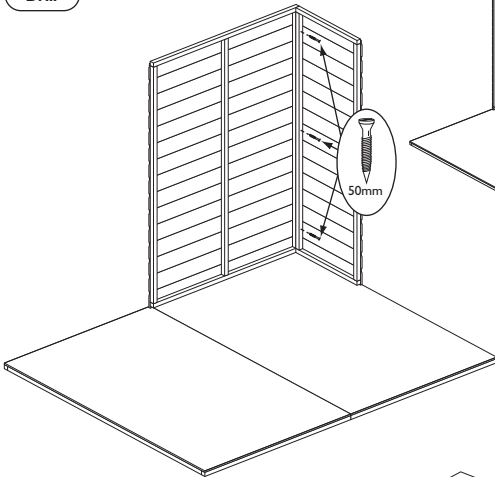

Assembly tip.

The window panels can be interchanged with any of the large panels on the side or back of the building.

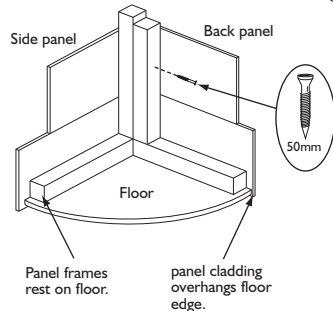

Important Note: Ensure correct orientation of front panels. Make sure the rebate edges face inward for the door to fit in.

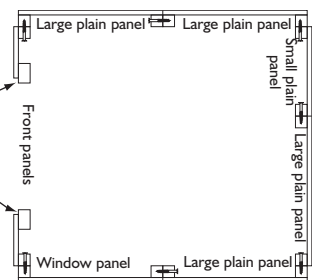

3. Securing the walls to the floor

Ensure the panels are sitting square on the floor. Secure using 16 x 65mm screws, screw through the panel frames and floor into the floor bearers.

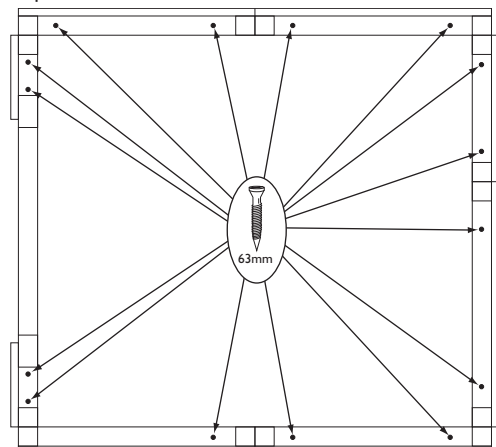
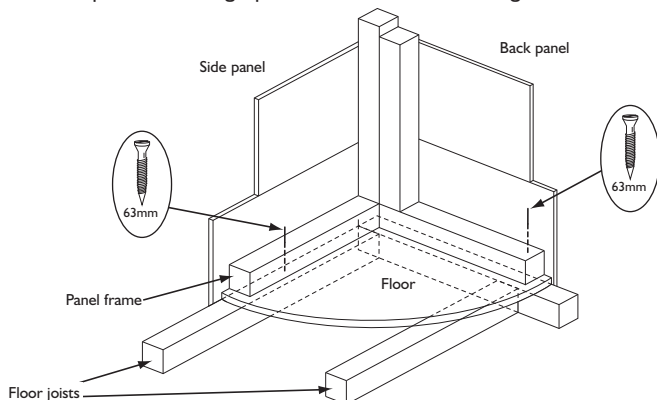

4. Apex panels and door header rail

Place an apex panel on top of the back panel, make sure the bottom shiplap board of the apex panel fits correctly into the shiplap board of the back panel. Secure by using 2 x 50mm screws, screw up through the top frame of the back panel into the bottom frame of the apex panel. Repeat for front apex. Attach to the front apex the door header rail using 2 x 50mm screws. Secure it flush to the bottom of the apex framing as shown.



It is recommended to drill pilot holes with a 4mm drill for each screw.

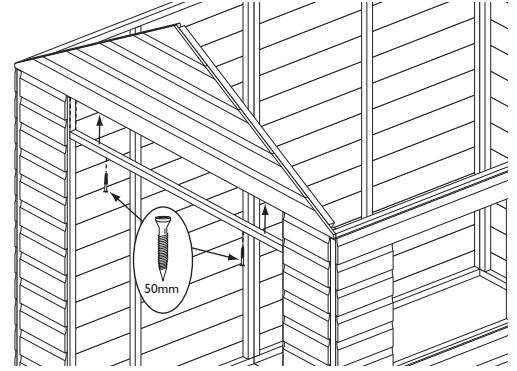
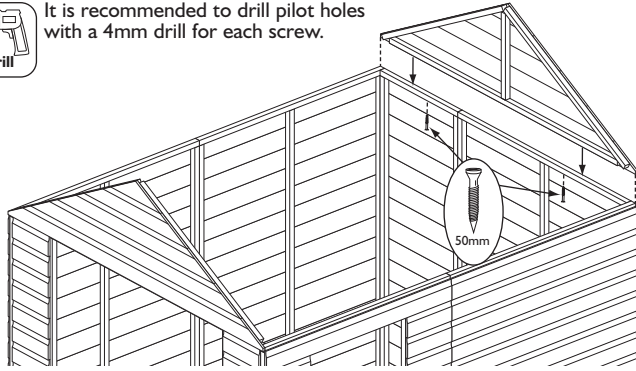

5. Roof sections

To the first roof panel secure a roof rafter flush to the right-hand edge of the panel, ensure the correct angled end of the rafter is flush to the short edge of the panel as shown below. Attach using 4 x 30mm nails, nail through the panel into the rafter. To the second panel attach two rafters in the same way as the first with one down each side of the panel. To the third panel attach a rafter down the Left-hand edge. Join the three panels together using 2 x 50mm screws per join, Screw through the the rafter of one panel into the rafter of the next as shown. Create a second roof section in the same way as the first.

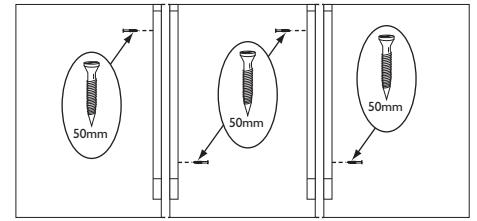
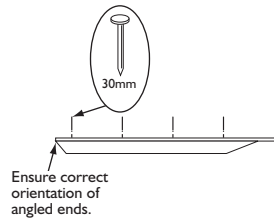
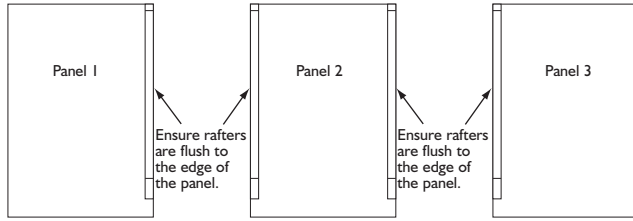

6. Roof sections

Secure to lower edge of both roof sections two felt battens using 5 x 30mm nails per batten as shown. Ensure the felt battens are flush to the edges of the panels. Flush to the front edges of each section attach the roof batten blocks evenly spaced along the edge using 2 x 30mm nails per block. Position the roof panels onto the building, make sure the top edges are located at the apex and the roof is flush with the back apex. Secure with 8 x 30mm screws per roof section, screw through the roof and into the panel framing. From inside the building fix a gusset to both sides of the two rafters using 2 x 30mm nails per gusset.

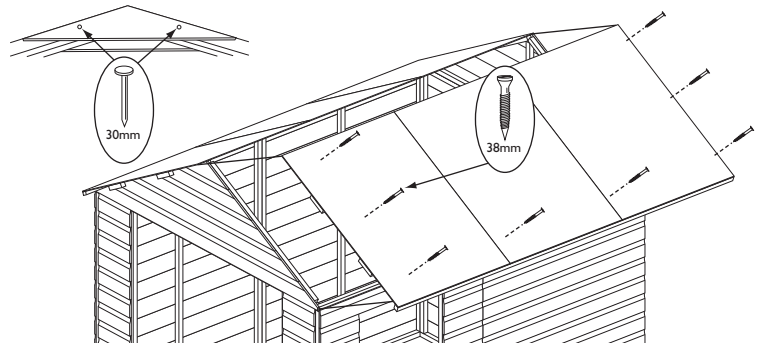
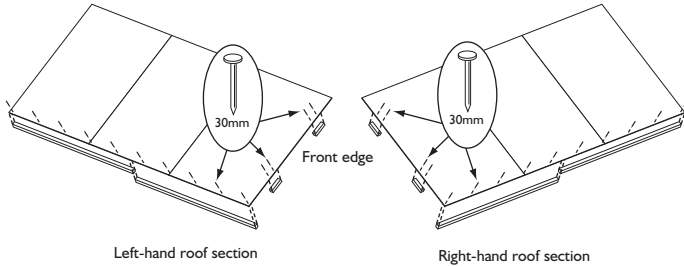

7. Roofing felt

Cut the 5m roofing felt roll into two equal lengths. Place one length over one roof section. At the front and along the lower edge of the roof leave an overhang of felt of at least 45mm. Fold down the felt along the lower edge and secure to the felt batten using 25 x 10mm felt nails evenly spaced. Tension the felt over the roof and secure along the upper edge using 4 x 10mm felt nails. Repeat this for the second piece of felt on the other half of the roof. Once the two pieces of felt are in place take the 2.5m ridge felt roll and place over the apex of the roof making sure it sits centrally over the roof ridge and overlaps the other two felt pieces, attach using 25 x 10mm felt nails evenly spaced, along each lower edge of the third felt. Dress down the ends of all felt pieces and attach to the Batten blocks at the front with 6 x 10mm felt nails. At the back secure to the apex panel using 6 x 10mm felt nails in the same way. When all the felt is in position trim of any excess.

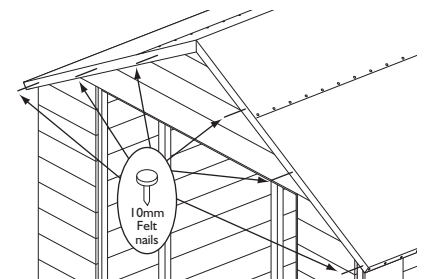
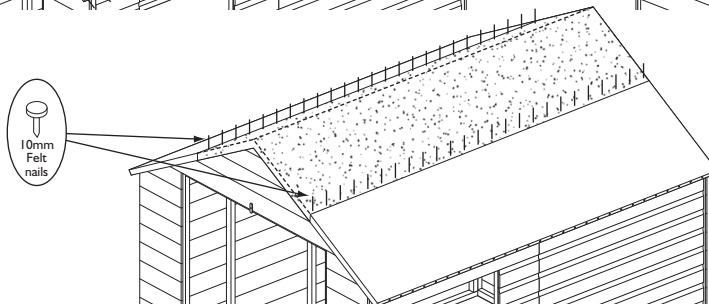
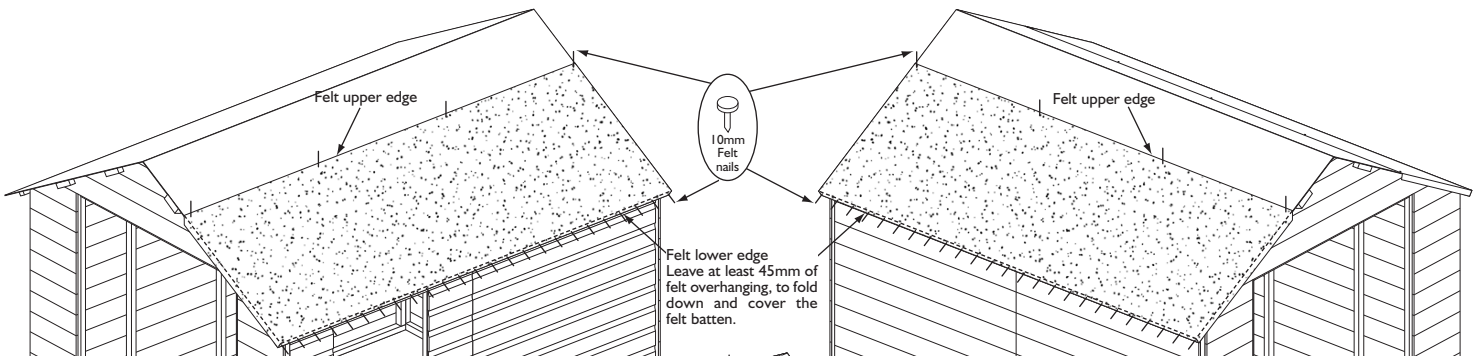

8. Coverstrips, bargeboards and finials

Fit a coverstrip into each corner, attach using 3 x 30mm nails per strip. The remaining three are used to cover the panel joins on each side and back, attach using 3 x 30mm nails per strip. Attach bargeboards at the front so that the top edge is flush with the roof line and the two boards meet evenly in the middle secure using 3 x 30mm nails per board. Repeat for the bargeboards on the back. On the front attach a finial centrally over the join between the bargeboards use 2 x 30mm nails. Repeat for the finial on the back.

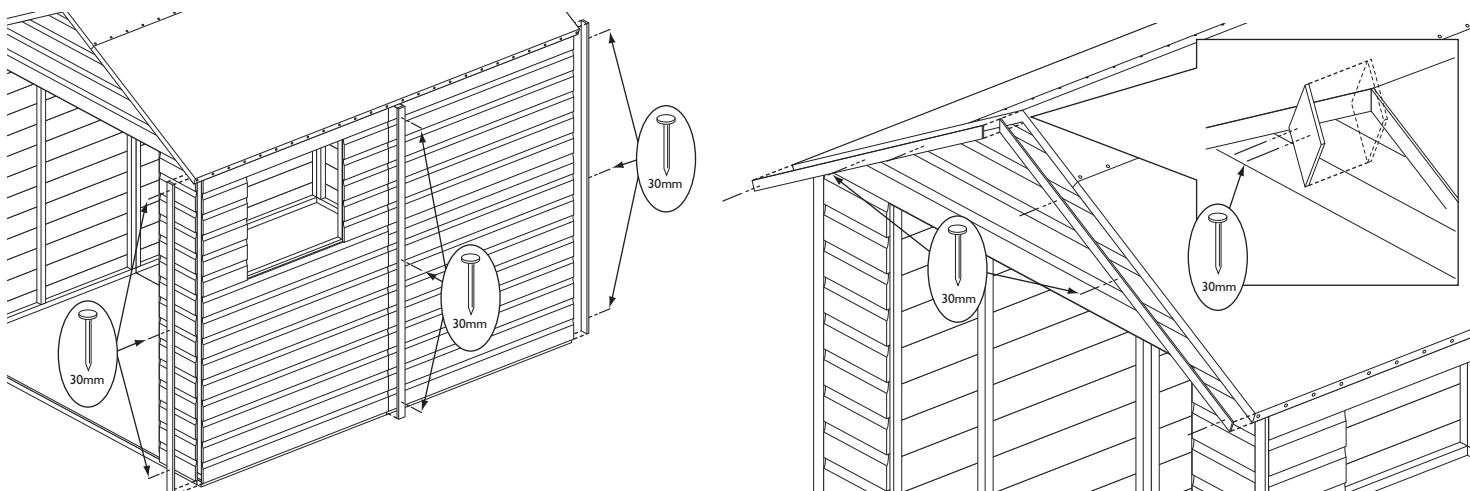

9. Fitting the door

Position the doors in the opening and secure each door in place with three T-hinges and 7 x 25mm screws per hinge as shown below. On the inside of the right-hand door secure the tower bolts to the mounting blocks using 4 x 19mm round head screws per bolt. With the doors shut, position a door coverstrip so it overlaps both doors and is flush at the top of the doors, secure only to left-hand door using 3 x 22mm screws. In the same way fix the other door coverstrip flush to the bottom of the door. Fit the hasp and staple between the two coverstrips using 7 x 19mm round head screws as shown below. Position the turn button just above the left-hand door secure to the apex panel using 1 x 22mm screw.

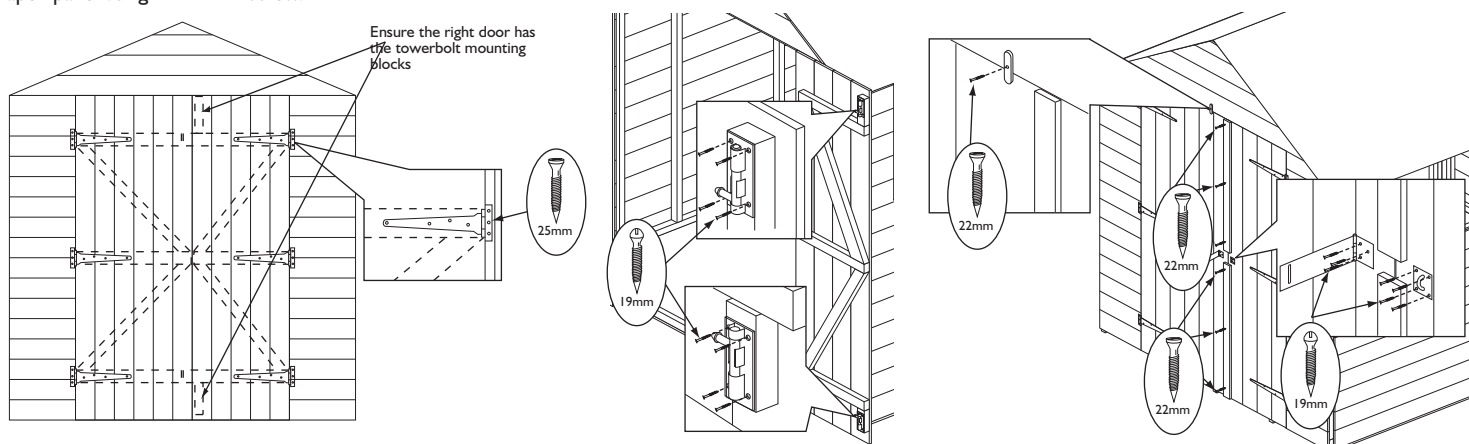

10. Glazing

It is recommended that a waterproof sealant is applied around the edge of the glazing before fitting. From the outside of the building fit the acrylic window into the plastic cill strip, fix the window in place with the wooden window beading strips at each side and the top using 3 x 20mm nails per beading strip. Add the window surround coverstrips as shown using 3 x 30mm nails for each strip.

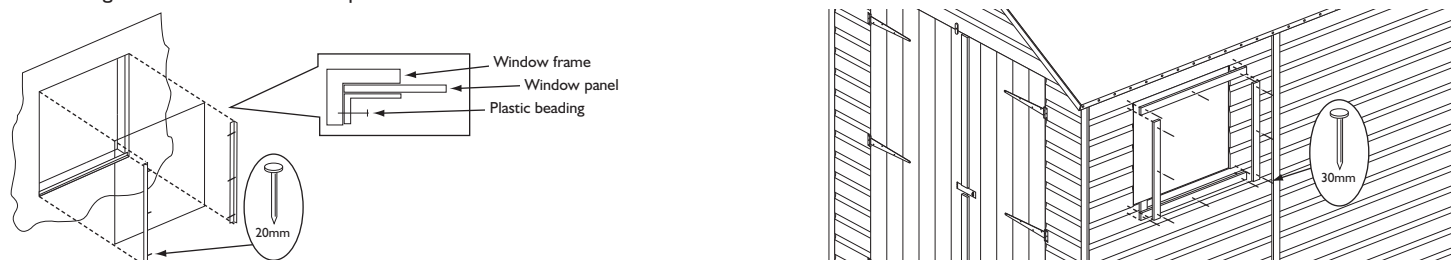

Important information - retain for future reference

To **VALIDATE** the guarantee, shiplap buildings come ready stained but this is only a preparatory treatment the building must be properly treated with a recognised external wood preserver **WITHIN 3 MONTHS** of assembly and **RE-TREATED ANNUALLY** thereafter.

Adequate provision must be made to ensure ground contact is avoided and air is able to circulate underneath the building. Placing the building on a concrete pad or slab base is acceptable provided that the building is not allowed to sit in pooled water during wet conditions. If the building is to sit on soil or grass it **MUST** be erected on additional pressure treated wooden 50mm x 50mm or similar bearers (**These are not supplied in the kit**).

Rowlinson Garden Products recommend using pressure treated bearers with all buildings on any type of base.

Timber Information.

As timber is a natural material, there are certain weather conditions that may affect the materials properties. In times of excessive dry spells the material may lose some of its internal moisture causing a certain degree of shrinkage on a panel and in periods of excessive rain there will be a certain amount of swelling throughout the wooden panels. This process can not be avoided. If you have problems with certain boards shrinking in dry spells try to decrease the amount of direct sunlight on the building or the amount of air passing over the building. During hot spells spray water directly onto the panels with the aid of a garden hose.

If in doubt of any aspect regarding the assembly, use or safety of your building please contact us :

Help Line (Normal Office Hours) 01829 261121

ROWLINSON GARDEN PRODUCTS LIMITED
Green Lane
Wardle Nr. Nantwich
Cheshire
CW5 6BN

We constantly improve the quality of our products, occasionally the components may differ from the components shown and are only correct at time of printing. We reserve the right to change the specification of our products without prior notice.

2008 © Rowlinson Garden Products Ltd